

	High voltage transducer	Document Nr	Rev. 00
		CSP111_EN_B_R00	Sheet 1 of 4

PRODUCT DESCRIPTION

The high voltage transducer is a product for measure DC or AC voltage up to 1500 Vac rms in the CSP111B_1500 version and up to 2100 Vac rms in the CSP111B version.

The input voltage signal is attenuated by several resistor, then the voltage is converted to low level signal by a LEM transducer powered by a DC/DC converter, finally the output voltage of the transducer is amplified to a signal up to 10Vrms.

The high voltage transducer consists of four part:

a LEM high voltage transducer,

a series resistor,

a DC/DC converter for insulate the high voltage input signal from the low voltage output signal,

an amplifier for adapt the high voltage transducer output signal to the required low level output signal.

The high voltage transducer consist of the CV3-2000 product of the company LEM, this transducer require a supply of a $\pm 15V=$ insulated from the AC measured voltage, the AC inputs voltage are marked with the HT+ and HT- terminal.

The maximum AC input voltage of the CV3-2000 transducer applied to the terminal HT+ and HT- is equal to 1400 Vac, for extending the measured voltage a series resistor is inserted from the input signal to the voltage terminal of the LEM transducer, in other words the AC voltage to be measured is connected to the CSP111B board and then after the series resistor, the AC voltage is connected to the HT+, HT- terminal of the LEM transducer.

The described input resistors are equal to 2 resistors of 50 kOhm value for extending the AC voltage up to 1500 Vac, this non inductive resistor are integrated inside the CSP111B_1500 board.

The described input resistors are equal to 4 resistors of 100 kOhm value for extending the AC voltage up to 2100 Vac, this non inductive resistor are integrated inside the CSP111B board.

Inside the CSP111B board the $\pm 24V=$ supply input voltage is converter to a dual voltage $\pm 15V=$ by an insulated DC/DC converter of 7.5W output power and a insulation voltage level of 2000 Vdc from the 24V= input power supply.

The dual $\pm 15V=$ is applied to the LEM transducer voltage, the output signal of the transducer will be present from the M and 0V terminal, this voltage is amplified from a non inverting amplifier stage with a variable gain from 1.4 to 2.32 (in the factory setting) or with a fixed gain of 1.6 (other setting).

The functional diagram of the voltage transducer is shown below (note, for the CSP111B model, the nominal input voltage is equal to 2100Vac)

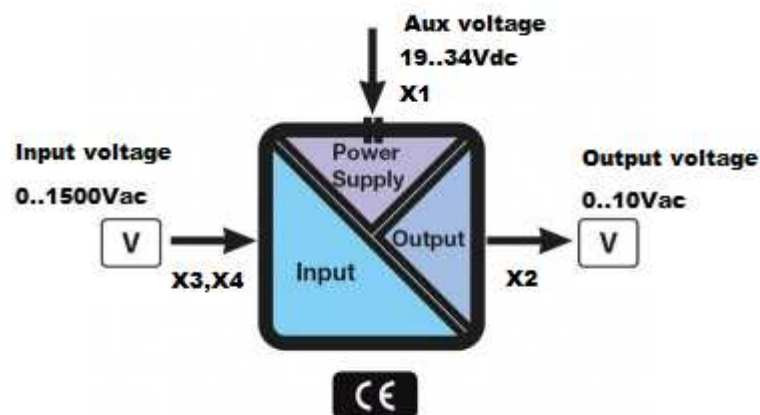



Fig. 1 - CSP111B logical diagram

	High voltage transducer	Document Nr	Rev. 00
		CSP111_EN_B_R00	Sheet 2 of 4

TECHNICAL FEATURES

The following technical features are valid for the voltage transducer CSP111B and CSP111B_1500:

Electrical data	
Power Supply	Min 19 V ₌ , Max 34V ₌
Consumption	Max 250mA at 19V ₌ , V input max and Load resistor = 68 Ohm
Input impedance from input voltage + and – pole	740 kOhm for the CSP111B_1500 transducer, 1040 kOhm for the CSP111B transducer.
Transducer type	Closed loop (compensated) voltage transducer
Nominal Input voltage CSP111B_1500 type	1500 Vac or dc
Bandwidth CSP111B_1500 type	13kHz
Nominal Input voltage CSP111B type	2100 Vac or dc
Bandwidth CSP111B type	100 MHz
Output voltage range (Load resistor = 1,5kOhm)	10 Vac rms *
Output voltage range (Load resistor = 270Ohm)	9 Vac rms *
Output voltage range (Load resistor = 135Ohm)	8 Vac rms *
Output voltage range (Load resistor = 85Ohm)	7 Vac rms *
Minimum load resistor	68 Ohm 1W
Insulation voltage from input to output	6kVac for 1 minute
Insulation voltage from 24 DC input to output	2kVdc 1kVac for 1 minute
Led meaning	+24Vdc input present
Connections	Spring terminal 1..2,5 mm ² for X1, X3, X4, X5, X6 Spring terminal 0,25..1,5 mm ² for X2
Standards	Safety EN60950-1:2006 +A12:2011 Electronic equipment for use in power installations: EN50178 CE

* With the factory setting gain = 1.6 (Jumper JP1=on, JP2=off).

	High voltage transducer	Document Nr	Rev. 00
		CSP111_EN_B_R00	Sheet 3 of 4

Mechanical data	
Dimension (length x width x height)	140 x 110 x 90 mm
Mass	700 g.
Transducer fastening	3 holes diameter 5.5mm, 3xM5 steel screws
Housing material	Plastic, recognized according to UL 94-V0
Vibration and shock load	In accordance with EN 60721-3-2 In accordance with EN 60068-2-6
Protection degree EN60529	IP00 without the cover, IP20 with the cover
Cooling system	Natural convection
Ambient conditions	
Operating	-10°C to +65°C Humidity 30..90% at 40°C (non condensing)
Storage	Class 1K3 to EN 60721-3-1 and temperature range -40°C to + 70°C
Transportation	Class 2K4 to EN 60721-3-2 and temperature range -40°C to + 70°C
Operation	Class 3K3 to EN 60721-3-3
Installation altitude	< 2000 m above sea level
Conformity	CE (Low voltage and EMC Directives)

ELECTRICAL DIAGRAM

A typical connection of the high voltage transducer is showed below:

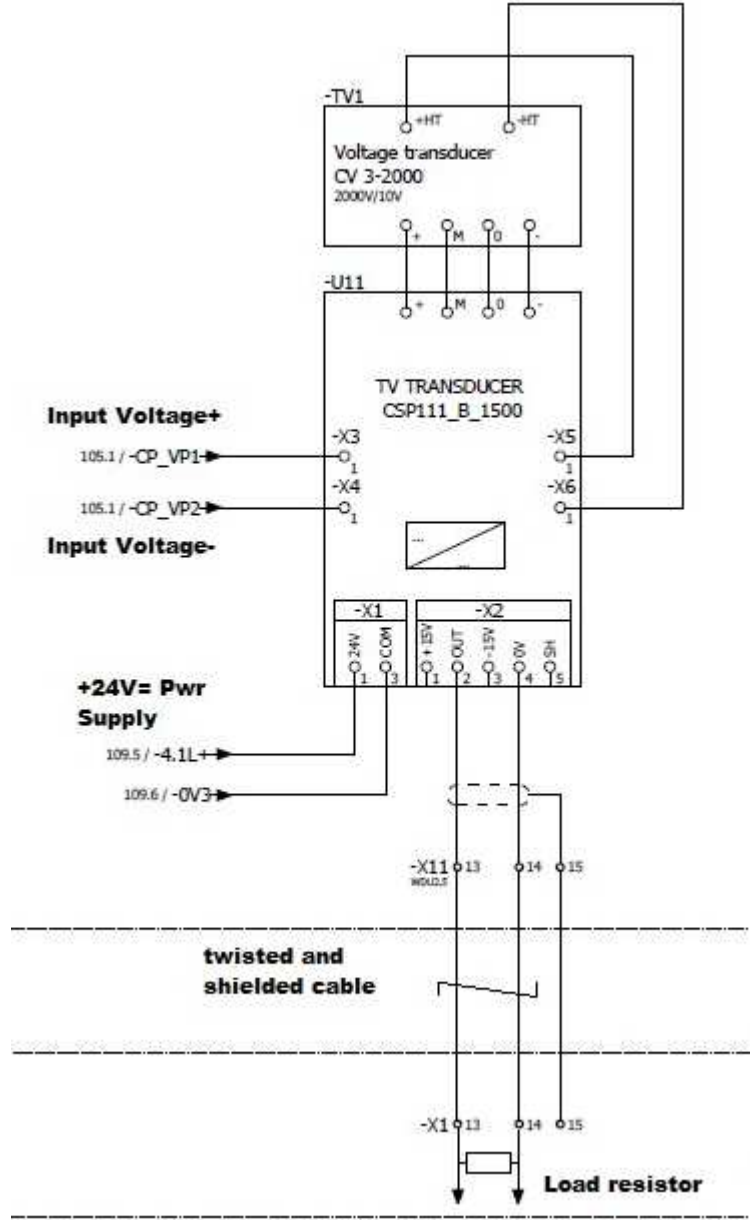

Fig. 2 - CSP111B example of connection